

UNLESS OTHERWISE SPECIFIED: DIMENSIONS ARE IN MILLIMETERS SURFACE FINISH: TOLERANCES: LINEAR: ±1 ANGULAR: ±1		Legal Owner:	MATERIAL:
Projection Method:		TITLE:	PROCESS:
PART NO: 620 TROMMEL WORKING POSITION		APPROVED BY:	FINISH:
REVISION:	SHEET: 1 OF 2	FORMAT: A3	QUANTITY:
CREATED BY:			WEIGHT (KG):
19/04/2024			APPROVED BY:
SCALE: NOT TO SCALE			

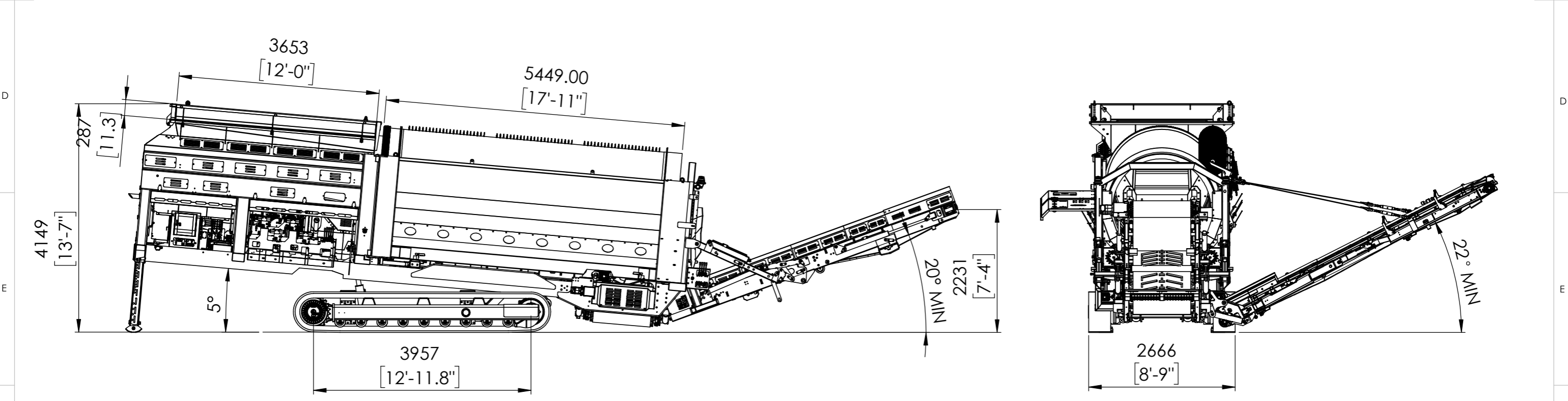
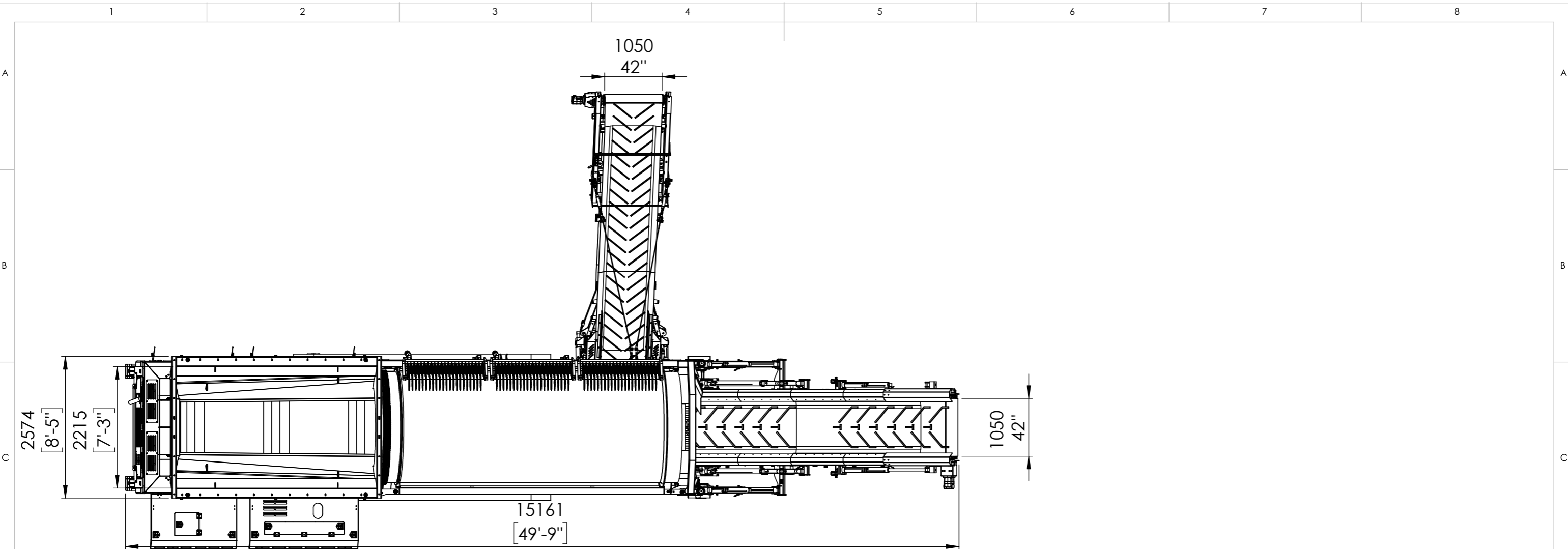

UNLESS OTHERWISE SPECIFIED: DIMENSIONS ARE IN MILLIMETERS SURFACE FINISH: TOLERANCES: LINEAR: ±1 ANGULAR: ±1		MATERIAL:	
Projection Method: THIRD ANGLE		PROCESS:	
TITLE:		FINISH:	
PART NO: 620 TROMMEL WORKING POSITION		QUANTITY:	
		WEIGHT (KG):	
		APPROVED BY:	
		CREATED BY:	
		19/04/2024	
		REVISION:	SHEET: 2 OF 2
			FORMAT: A3
			SCALE: NOT TO SCALE